

LIFUD®

150W
IP65
160
lm/W



LIFUD®

LIFUD®



Industrial LED High Bay - LIFUD Driver - 150W - 160lm/W - PHILIPS Chip - Dimmable 1-10V - IP65

Ref. B8138-150

High-power industrial LED high bay light of 150W at 220-240V/AC and high luminous efficiency. With extra-flat and light circular design, which allows easy and quick installation. Available in warm white (3000K), neutral white (4000K) and cool white (5000K) ideal for industrial warehouses, large surfaces, workshops, sports and recreational spaces. Manufactured with Philips Lumileds LEDs of maximum efficiency, with 160lm/chips that will allow you to save on your electricity bill .Driver LIFUD dimmable 1-10V

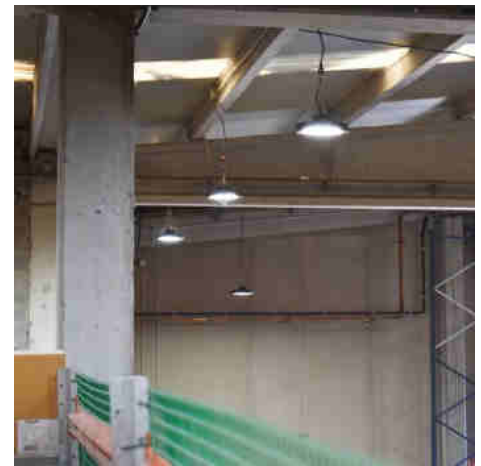

Product data

Kelvin (K)	3000, 4000, 5000
Power (W)	150
Nominal Voltage (V)	220 - 240 V/AC
Material	Metal
IP	IP65
Certificates	CE, ROHS
Discount	Professional lighting, Professional lighting up to 80% off

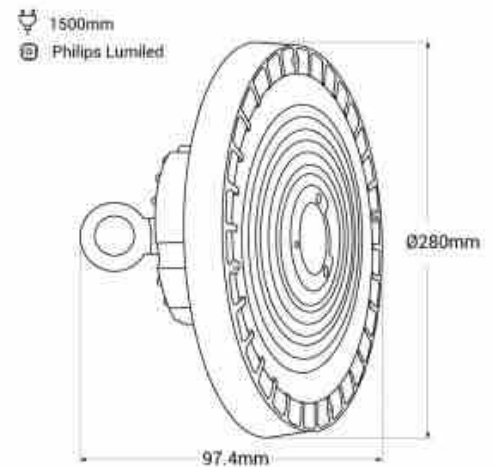

Product variants

Reference

Attributes

B8138-150-3K

Colour temperature - Warm white 3000K



B8138-150-4K

Colour temperature - Neutral white 4000K

