

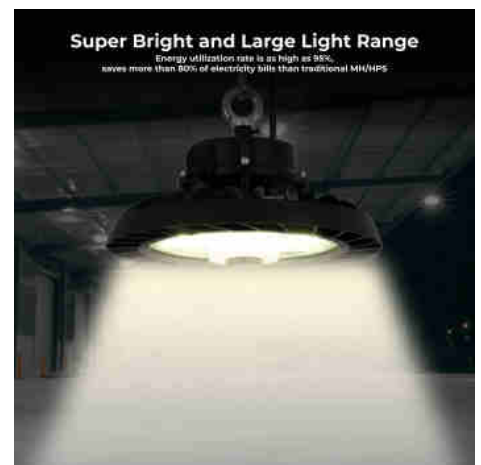

Industrial LED UFO High Bay - 150W - CCT - 170lm/W - LIFUD Driver - IP65 - 5 years warranty

Ref. B8155-150W-3CCT

150W Industrial LED High Bay with high efficiency: 170lm/W and Lifud Driver. It stands out for its robust design, high quality, and versatility. It features a power regulation switch and is compatible with sensors and DALI control. It incorporates a CCT system for colour temperature adjustment between warm white (3000K), neutral white (4000K), and cool white (5000K).**5 years warranty**



Product data

Hue	CCT
Kelvin (K)	3000, 4000, 5000
Lumens (Lm)	22800
Efficiency (Lm/w)	170
CRI	70-80
Beam angle (°)	90°
Dimmable	Yes
Power (W)	130, 150, 100
Nominal Voltage (V)	220 - 240 V/AC
Frequency (Hz)	50 - 60
Driver	Internal, LIFUD
Sensor	Yes
Orientable	Yes
Material	Aluminium
Diffuser material	Polycarbonate
IP	IP65
Frequency of use	Intensive
Lifetime (h)	50000

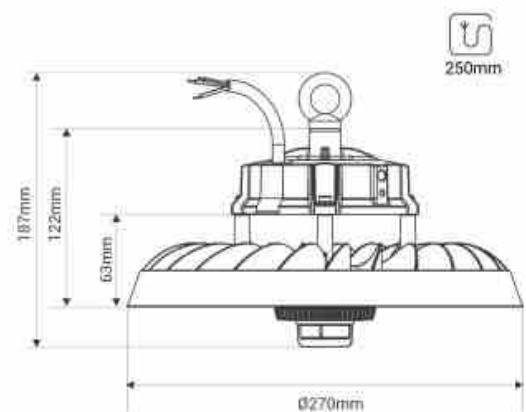

UFO LED High Bay Light

Energy efficiency class	B
Certificates	CE, ROHS
Warranty	5 years
IK	09
Width	Ø270mm
Height	187mm